

# Why Bodewell



为什么选择我们



产品创新  
Product Innovation

- 四大产品系列，满足不同场景需求  
Four product series to meet different requirement

- SS系列满足离线、较低产量需求  
SS series is suitable for offline requirement

- TS系列满足在线、每小时30托以内的需求  
TS series is suitable for online, UPH:30 pallets/hour

- TSS系列满足在线、每小时70托以上的需求，并且可以选配护纸功能  
TSS series is suitable for online,UPH up to :70 pallets/hour,according to customer requirements optional paper protection function



技术创新  
Technological Innovation

- 高频摩擦焊接、搭接强度85%以上，更能保护货物安全  
High frequency friction welding,joint connect strength up to 80%, and protect load safety while transportation

- 超低穿剑高度、无需做地坑，省成本  
Ultra-low drive lance height, can install the machine quickly without foundation work and operator can transport the pallet load direct into machine with forklift

- 全系配备压紧功能，更好实现蓬松纸板的捆扎加固  
All machine can equipemted with compression function which can help get better bundle effect



高效稳定  
Efficient Stabilize

- 双机头设计、高速导轨设计，满足每小时70托以上的产能  
Dual strapping head , high-speed carriage , up to the production capacity of 70 pallets/hour

- 自有精密五轴加工中心加工核心零部件，承诺50万次免更换  
Our company has precision 5-axis processing center, it can process the core parts. We promise 500,000 free replacements

- 打带成功率承诺99.5%以上，最大程度减少非计划停机时间  
Band success rate promises 99.5% or more, minimizing unplanned downtime

- 华北地区  
河北、山西、内蒙古

- 西北地区  
青海、甘肃、宁夏、陕西

- 西南地区  
四川、云南、贵州

- 东北地区  
吉林

- 华中地区  
湖北、湖南、河南

- 华东地区  
山东、江苏、安徽、福建、浙江、江西

- 华南地区  
广东、广西、海南

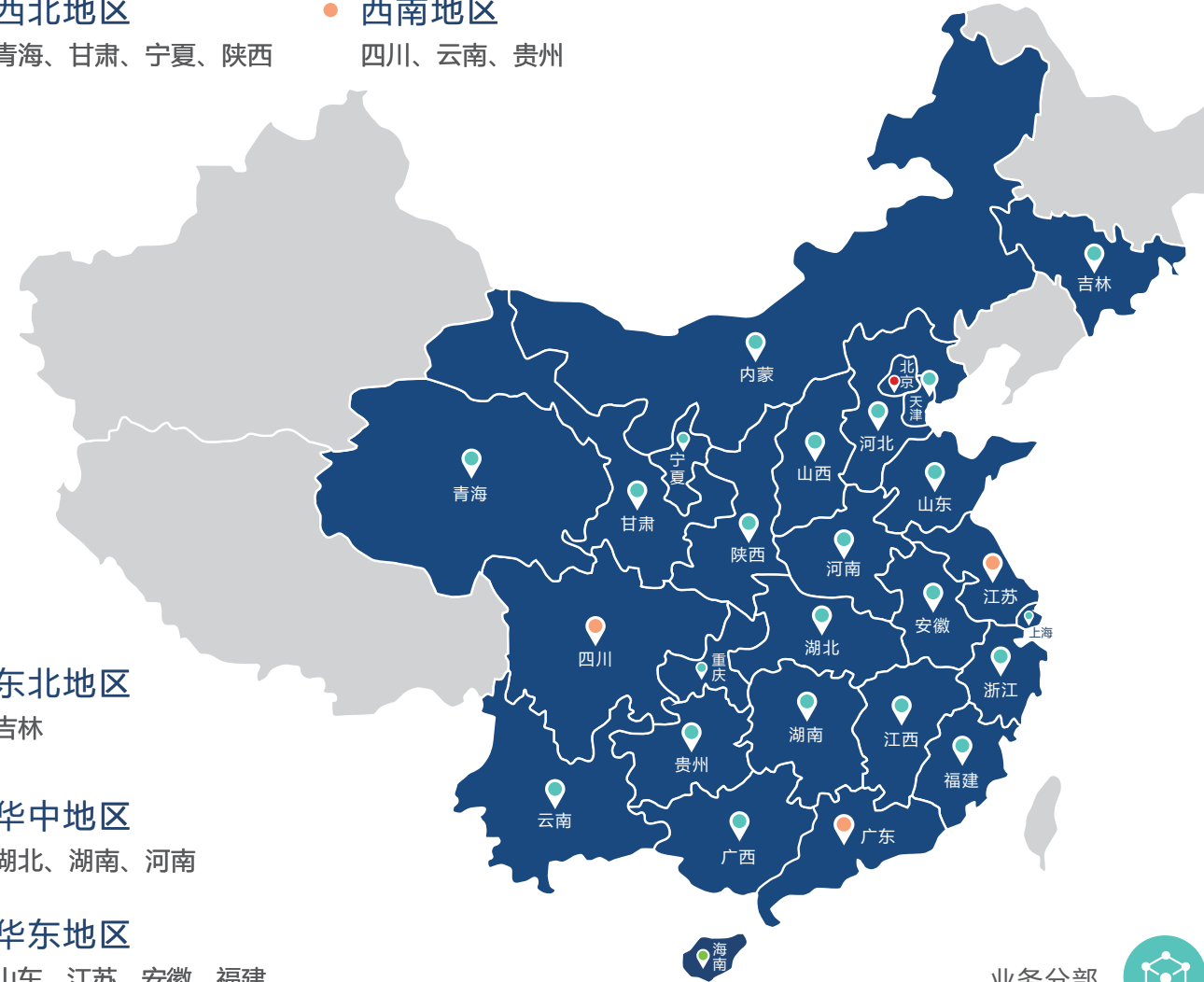

业务分部

生产基地/研发中心

珠海博杰电子股份有限公司  
Zhuhai Bojay Electronics Co.,Ltd.

地址: 珠海市香洲区福田路10号  
Add: No. 10, Futian Rd, Xiangzhou District, Zhuhai, China

service@zhbojay.com

+86-756-8695300/8695871

www.zhbojay.com



关注博进抖音号  
探索更多案例  
more video case ...

免责声明: 1.本产品目录内容可能会在不预先通知的情况下有所变更。2.本产品目录为本公司著作物, 版权归我司所有, 转载或者引用本目录内容请注明来源; 未经允许不得随意转载, 否则将视为侵权并依法追究法律责任。

Disclaimer: 1. The catalog can be changed without pre-notice. 2. This catalog is the work of the company, copyright belongs to our company, reprinting or quoting this directory content, please specify the source, it is not allowed to be discontinued, otherwise it will be considered as infringement and investing in legal responsibility according to law.



瓦楞纸 智能打包解决方案

CORRUGATED PAPER  
INTELLIGENT STRAPPING SOLUTION

高速 /High speed  
满足70托/小时产能需求  
UPH: 70 pallets/hour

通用 /Universality  
适用10款以上卡板混流生产  
Suitable for more than 10 Kind of different size pallets

稳定 /Stable  
99.9%打带成功率, 降低非计划停机时间  
99.9% action success rate, reduce downtime

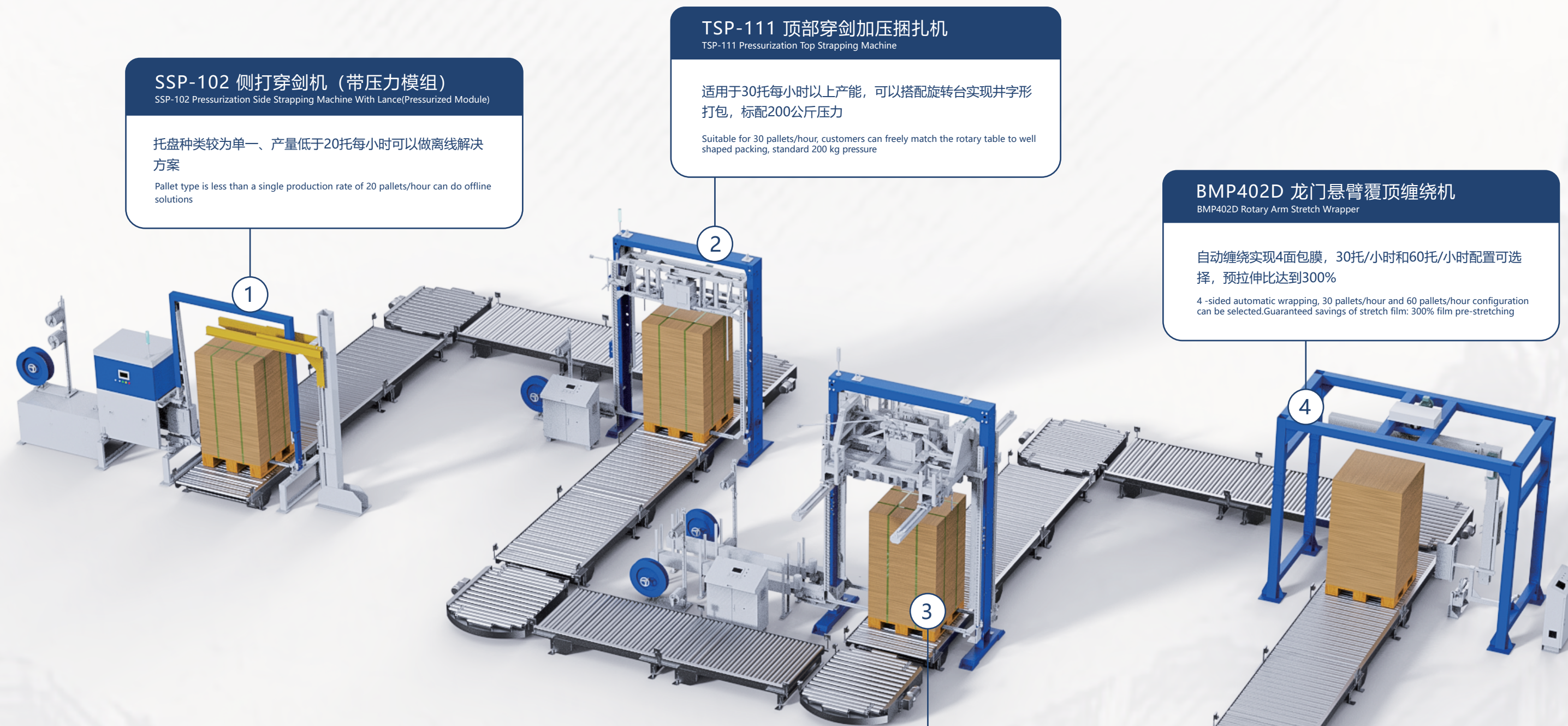

**SSP-102 侧打穿剑机 (带压力模组)**  
 SSP-102 Pressurization Side Strapping Machine With Lance(Pressurized Module)

托盘种类较为单一、产量低于20托每小时可以做离线解决方案  
 Pallet type is less than a single production rate of 20 pallets/hour can do offline solutions

**TSP-111 顶部穿剑加压捆扎机**  
 TSP-111 Pressurization Top Strapping Machine

适用于30托每小时以上产能，可以搭配旋转台实现井字形打包，标配200公斤压力  
 Suitable for 30 pallets/hour, customers can freely match the rotary table to well shaped packing, standard 200 kg pressure

**BMP402D 龙门悬臂覆顶缠绕机**  
 BMP402D Rotary Arm Stretch Wrapper

自动缠绕实现4面包膜，30托/小时和60托/小时配置可选择，预拉伸比达到300%  
 4-sided automatic wrapping, 30 pallets/hour and 60 pallets/hour configuration can be selected. Guaranteed savings of stretch film: 300% film pre-stretching

**TSSAP-211 双机芯双穿剑加护角加压捆扎机**  
 TSSAP-211 Pressurization Strapping Machine X

适用于每小时70托以上产能，可以选配自动加护角功能最大可配4000公斤压力  
 Suitable for production capacity of 70 pallets/hour, customers can freely select the automatic corner function of automatic angle, maximum compatible 4000 kg pressure

瓦楞纸智能打包解决方案

**CORRUGATED PAPER**  
 INTELLIGENT STRAPPING SOLUTION



# BODEWELL

博进工业包装 STRAPPING SYSTEM

## SSP-102 侧打穿剑机（带压力模组）

SSP-102 Side Strapping Machine Combine Press Module

压力模组

Pressure module

模块化摩擦机芯

Modular friction strapping head

电动穿剑

Electric lance

适用于  
Applied to

托盘种类较为单一  
Single pallet type

产量低于20托/小时  
UPH below 20 pallets/hour

离线解决方案  
Offline solutions





# BODEWELL

博进工业包装 STRAPPING SYSTEM

## TSP-111 顶部穿剑加压捆扎机

TSP-111 Top Strapping Machine Combine Pressurization

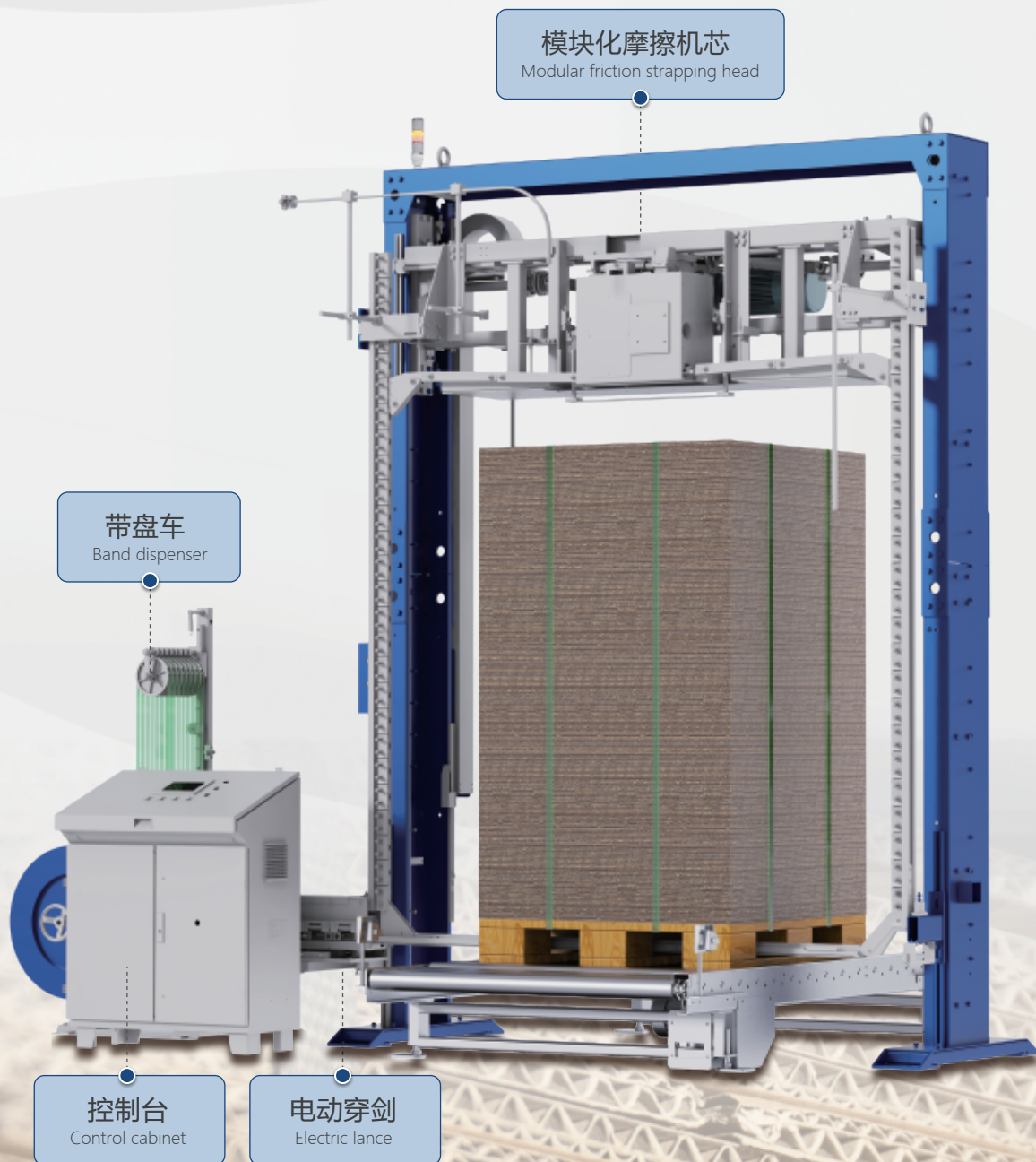

模块化摩擦机芯

Modular friction strapping head

带盘车

Band dispenser

控制台

Control cabinet

电动穿剑

Electric lance

适用于

Applied to

30托/小时以上产能  
UPH up to 30 pallets/hour

可以搭配旋转台实现井字形打包  
Combine with turn table to strap both side

标配200公斤压力  
Standard 200 kg pressure force

| 通用配置说明/General configuration |                                                     | 机台主参数/Machine Technical Data        |                                          |
|------------------------------|-----------------------------------------------------|-------------------------------------|------------------------------------------|
| PLC                          | 西门子 S7-200 smart/德国<br>Siemens S7-200 smart/Germany | 标准设备尺寸<br>General machine dimension | 5650*1212*3950(L*W*H)                    |
| 触摸屏<br>Touch panel           | 威纶通/台湾<br>Weinview/Tianwan                          | 捆紧力度<br>Tension force               | 200-2500N                                |
| 主电机<br>Lift motor            | 国茂/中国<br>Guomao/China                               | 顶部压力<br>Top pressure                | 200KG                                    |
| 开关器件<br>Switching devices    | 施耐德/法国<br>Schneider/France                          | 接口方式<br>System interface            | 摩擦焊接<br>Friction welding                 |
| 传感器<br>Sensor                | 欧姆龙/日本<br>Omron/Japan                               | 打包效率<br>Cycle time                  | 30托/小时 (2条带)<br>30pallets/hour(2 straps) |
| 机芯<br>Strapping head         | 博进工业包装<br>BODEWELL                                  | 标准货物尺寸<br>General package dimension | 1200*1200*2000(W*H)                      |



标配压力模组，应对蓬松纸板更好捆扎效果

Standard pressure module to deal with the better bundling effect



配备高品质摩擦机芯，99.5% 打带成功率

High quality friction strapping head



2年无易损件更换，超低使用成本

We promise that there will be no replacement of wearing parts for 2 years, ultra -low use cost



模块化设计，轻松加入现有产线

Modular design for easy introduction into existing production lines

## TSP-111 尺寸图

TSP-111 Dimension

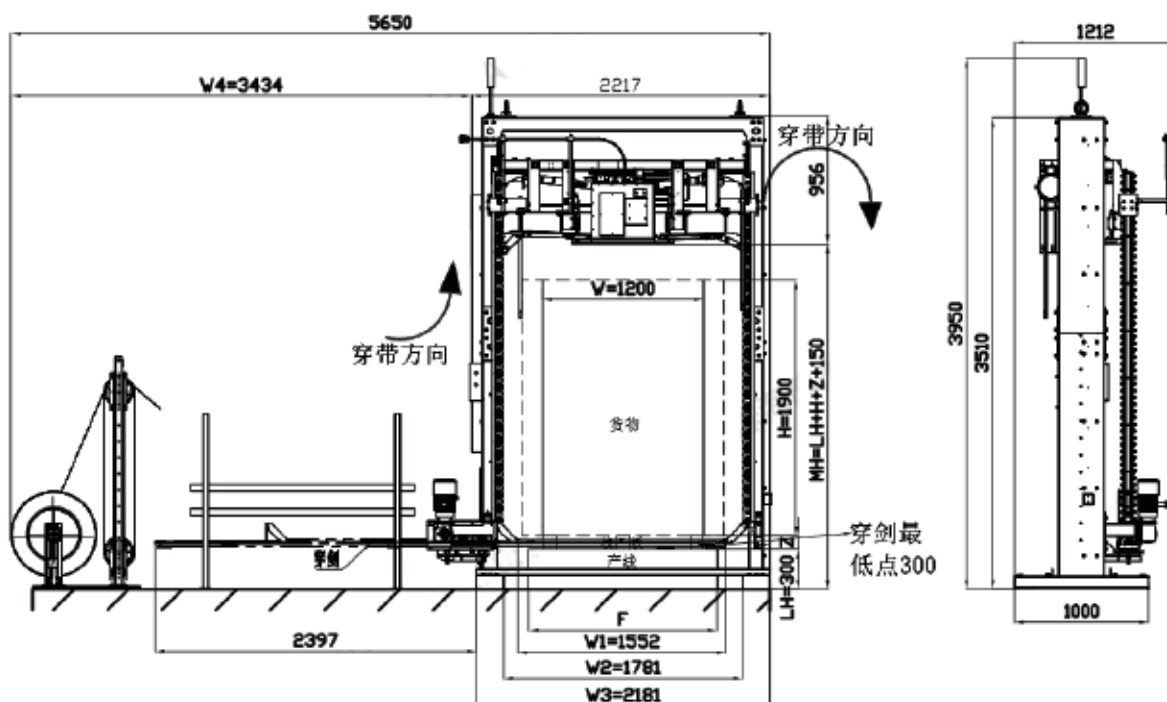



# BODEWELL

博进工业包装 STRAPPING SYSTEM

## TSSAP-211 双机芯双穿剑加护角加压捆扎机

TSSAP-211 Dual Strapping Combine Protect Paper And Press

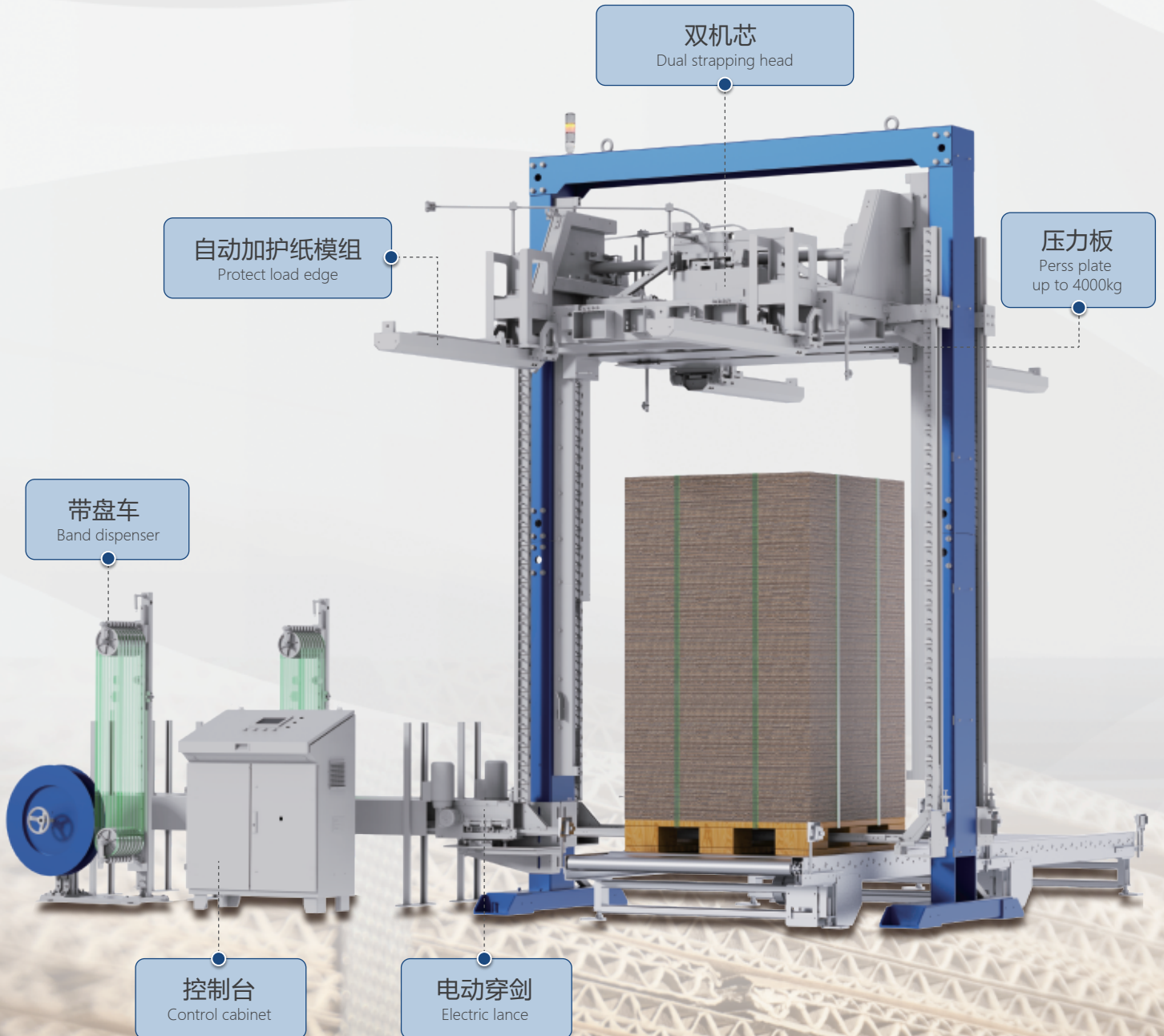

双机芯

Dual strapping head

自动加护纸模组

Protect load edge

压力板

Press plate  
up to 4000kg

带盘车

Band dispenser

控制台

Control cabinet

电动穿剑

Electric lance

适用于  
Applied to

70托/小时以上产能  
UPH up to 70 pallets/hour

可选配自动加护角功能

Customers can freely select the automatic corner function of automatic angle

最大可配4000公斤压力

Maximum compatible 4000kg pressure force

## 通用配置说明/General configuration

|                           |                                                     |
|---------------------------|-----------------------------------------------------|
| PLC                       | 西门子 ST-200 smart/德国<br>Siemens ST-200 smart/Germany |
| 触摸屏<br>Touch panel        | 威纶通/台湾<br>Weinview/Tianwan                          |
| 主电机<br>Lift Motor         | 国茂/中国<br>Guomao/China                               |
| 开关器件<br>Switching devices | 施耐德/法国<br>Schneider/France                          |
| 传感器<br>Sensor             | 欧姆龙/日本<br>Omron/Japan                               |
| 机芯<br>Strapping head      | 博进工业包装<br>BODEWELL                                  |

## 机台主参数/Machine Technical Data

|                                     |                                          |
|-------------------------------------|------------------------------------------|
| 标准设备尺寸<br>General machine dimension | 5534*2100*4570(L*W*H)                    |
| 捆紧力度<br>Tension force               | 200-2500N                                |
| 顶部压力<br>Top pressure                | 最大4000KG<br>Maximum 4000KG               |
| 接口方式<br>System interface            | 摩擦焊接<br>Friction welding                 |
| 打包效率<br>Cycle time                  | 70托/小时 (2条带)<br>70pallets/hour(2 straps) |
| 标准货物尺寸<br>General package dimension | 1600*2000*2300(W*H)                      |



高性能的高频摩擦机芯，保证接口强度的同时无需维护热刀

High quality friction strapping head, ensure the interface strength and no hot knife maintenance

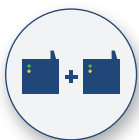

双机芯，打包效率更高

Equipment with dual strapping head,UPH up to 75 pallets/hours



配备压力板，压力最大可达4000kg，更好应对蓬松货物

Equipment with press plate, up to 4000kg press force for better strapping



选配加护纸功能，更好保护货物

Protection paper dispenser is optional

## TSSAP-211 尺寸图

TSSAP-211 Dimension

